



FEATURES & SPECIFICATIONS:

Construction

- Marine Grade die-cast aluminum housing
- Oxidized Hammer Finish and two high-durability polyester powder coating layers
- Marine Grade stainless steel hardware & mounting
- Stainless steel cable glands with adapter from M20 to 3/4"
- Enclosure color silver, other colors available

Optical System

- Light Source: CREE | XT-E | S4 LED's
- Color Temperature: 5000K (standard), 2800-5700K special order
- Various Lumen Packages: 5,400 - 9,000 Lumens
- 150 Lumens Per Watt
- 120° Optics. 17°, 25°, 40°, 60° & 80° available special order

Electrical System

- LED Driver Protection: Overload, temperature, short-circuit and surge protection
- 110-277V, 50/60HZ replaceable driver

Weight & Dimensions:

- 5.9" x 3.3"
- 2 lbs

Other

- Rated life 100,000 hours at 25°C
- 5 year warranty

LISTINGS:

UL 844 for Use in Hazardous Locations
UL 1598A Marine Outside Type (Saltwater)
CSA C22.2 No. 250.0
CSA C22.2 No. 137
IP66

Class I Division 2 Groups A, B, C, D
Class II Division 1 and 2 Groups E, F
Class III

Class I Zone 2 Group IIC T6
Class II Zone 20, 21, or 22 Group IIB T6
1Ex d IIC T5
-60°C to +55°C
-60°C to +65°C (Optional)

APPLICATIONS:

Coastal Marine Areas
Chemical Plants
Pharmaceutical Plants
Wastewater Treatment Plants
Hazardous Storage Facilities
Cold Storage Facilities
Corrosive Environments
Shipyards / Marine Vessels
Subzero Storage
Modular Skids / Buildings
Elevator Shafts
Tunnels

9400 SERIES

ORDERING INFORMATION

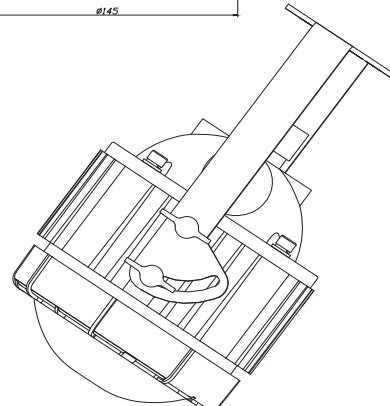
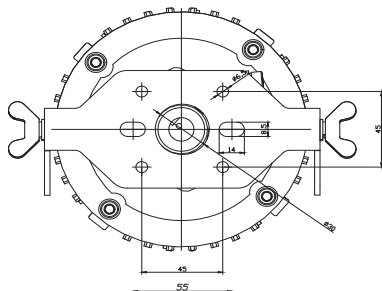
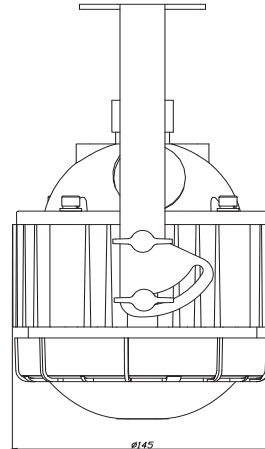
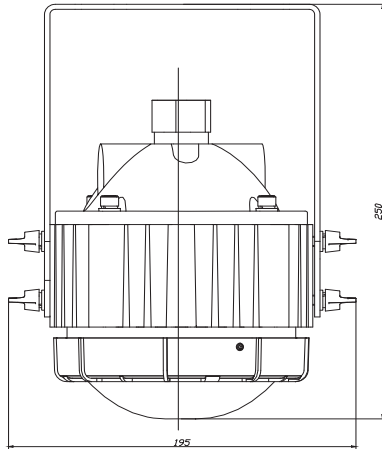
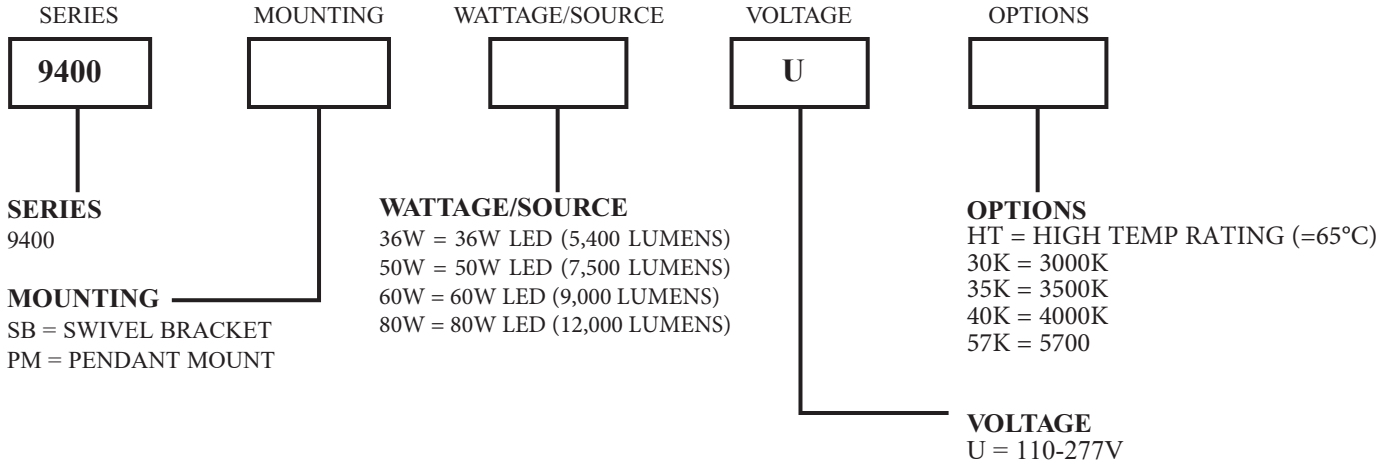

SNELSON OILFIELD LIGHTING
 8622 FAIRBANKS N HOUSTON
 HOUSTON, TX 77064

www.snelsonlights.com

Phone 713-937-3600
 Phone 866-563-2832